

# PETE SCHIECK

Systems Engineer

229 220<sup>th</sup> Place  
Manhattan Beach, CA 90266  
Cell: (310) 739-5973  
[pete@peteschieck.com](mailto:pete@peteschieck.com)

- Senior Software Engineer – .Net (ASP.Net, C#), SQL Server, IEC (Ladder, Function Block, SFC, Structured Text), Mac/Win porting, migration
- Hardware Engineer – Analog/Digital I/O (Allen-Bradley, Schneider, Honeywell, Tridium, Wonderware, Modbus/TCP, BACnet, LON, Phoenix Contact, Keyence, Johnson/Metasys, Trane), machine vision (Matrox MIL, Cognex Insight), motion control, AutoCAD, device driver development (C++), OPC, real-time database integration, streaming multimedia servers, and Macintosh systems engineering
- Sales Engineering – embedded, .Net customized applications, industrial/factory automation (combustion, manufacturing, robotics, packager/palletizer, pharmaceutical manufacturing), hardware/software integration, training, presentations, surveys

## *Experience*

---

**George T. Hall**, Anaheim, CA  
Software Systems Engineer

2009 - Present

I handle “full lifecycle” design/build chores, business development, and training for systems integration in the Los Angeles area for this combustion/industrial-centric distributor. Also, there is a commercial enterprise integration profile (Honeywell Tridium/Niagara), including panel fabrication, installation, configuration, service, programming, and commissioning.

**Independent Consultant**, Western United States  
Engineering, Technical Writing, Business Development

1985 – 1999, 2001 - Present

**Electrical Design & Motor Control (2009 - Present)** – Wonderware and SQL Historian programming and training. Recipe Manager, RAID Storage, .Net integration, Driver Install/Configure, startup/commissioning, documentation (ISO 9001, 21 CFR Part 11, Air Quality Management District, EPA/FDA, LEEDS)

**State of California, 3<sup>rd</sup> District, Court of Appeals (1994)** – developed macros, scripting and database development, tutoring/mentoring

**Meta Research (1985-1988)** – Statistical data processing, surveys, technical support

**Geremia Pools (1997-1999)** – production, testing, water chemistry, installations, configurations, programming controls

**Olan Mills (2001 - 2003)** - business development, traveling assignments

**Saber Engineering**, Sacramento, CA  
Project Engineer

June 2006 – July 2008

My engineering projects centered around machine-building, robotics, wastewater automation, laser/photovoltaics, PLC integration, and real-time (deterministic) database programming. Full lifecycle, complete plant SCADA systems were consistently developed. Golden State Water, for example, had a plant rebuilt (PLCs dismantled, rebuilt) and full historian deployed over 1000+ billable hours. Another example would be a machine vision solution I implemented for a major pharmaceutical manufacturer (printer packaging verification/validation).

**Apple Computer**, San Francisco, CA  
Inside/Outside Sales, Server Business Development

1999 – 2001

As an original member of the Apple Store internal team, I was involved in the rollout of the first 25 retail properties. *Consumer Reports* said that my team was #1 in customer satisfaction in the industry.

- Provided server-level consulting including advising and developing for heterogeneous data centers (RAID, SAN, MS SQL Server), enterprise architecture (clusters, IP), and multimedia solutions.
- Set world-wide sales records for Apple servers. This included fielding hundreds of calls per month regarding servers, enterprise architecture/development, and multimedia production-caliber engineering.

**United Cerebral Palsy**, Sacramento, CA  
Managing Caseworker & Technologist

1989 - 1992

- Ran the United Cerebral Palsy Center's Toy Lending facility as well as the Computer Center while handling a standard caseload in the field of adults and children with physical and/or developmental disabilities.
- Developed assistive technologies for use in the center – this included hardware, software and other instrumentation. Trained staff and end users. Programming tools used included: Pascal, Basic and Assembler.
- Marketed the UCP organization through special event productions, dances and concerts.

**Bill Graham Presents**, Sacramento, CA  
Manager, Business Development/Sales, Engineering Services

1985 – Current

This company was recently acquired by **Clear Channel Communications**. Although I am still an employee, I am occasionally consulting and producing special events.

- Manage the usher program at Cal Expo Amphitheatre (1987 - 1990).
- On-tour, traveling management (Pink Floyd, Grateful Dead)

## *Education & Certifications*

---

### **Psychology/Philosophy**

California State University, Sacramento, 1985-1989

Nationally awarded member of forensics team – 2 years  
Concert Production Executive – 4 years

- Certifications in Wonderware InTouch 9.5, Honeywell Tridium (I, II) and Station Designer Software, Allen-Bradley Ladder programming, and Citect SCADA (6.1 Networking & Architecture, Customization & Design)
- Apple Authorized Business Agent (2004 – 2006), Certified Apple Product Specialist (1999 – Present)
- Phoenix Contact IEC Programming and Industrial Web Server Development
- Professional Selling Skills (PSS) Certificate
- Alcoa Sales Certificate
- GE Fanuc Proficy (Fix32, iFix) HMI/SCADA

## *Other Qualifications*

---

### **Instructor**

AutoCad, Office (including programming VSTO/VBA), Adobe Creative Suite, Apple Pro Applications (audio/video, mastering, vocal/music trainer), SCADA/Historian (several platforms), VisualStudio.Net, Internet Marketing, Algebra/Trig, Chemistry, Geometry and other subjects.

- Mad Science                      2008 - Present
- EZ-Tutoring                      2005 – Present

### **Event Producer**

- Self-produced events at California State University, Sacramento, Cow Palace in San Francisco, and United Way.
- Performed with members of Santana, Grateful Dead, and Youngbloods.
- Performed for Lyrics Born, Mad Professor, Blackalicious, Inner Circle, and Presidents of The United States of America.

### **Volunteer**

Manage, market and promote events for community charities including: United Way, United Cerebral Palsy, Short Center, Alta Regional Center, Manhattan Beach Centennial Committee

### **References**

Ryan Bradley, Electrical Design and Motor Control  
(EDMCI.com, Roseville, CA)  
Greg Stepanian, Wonderware West  
(Lake Forest, CA)

# Functional References & Work Samples

By Pete Schieck  
(310) 739-5973  
pete@peteschieck.com

Multimedia systems engineering is my specialty, and design reviews/specifications are my best work. Also, I can build deterministic, crash-proof servers and workstations on Macintosh and Windows using redundancy in hardware and software. My best work includes:

1. Discrete-logic based lighting control systems (function block, structured text, Modbus/TCP)
2. Advanced conveyance and locomotion (Allen-Bradley ControlNet braking, Yaskawa micron-level actuation, Rockwell VFD)
3. Advanced Climate Control (Temperature, Rh, modulating or on/off VFD)
4. Machine vision and laser displacement
5. Fluid Displacement (>15 million gallon water feeders, advanced modulating valve systems)
6. Windows .Net and Apple Cocoa Multimedia Application Engineering (audio/video, acoustics, graphics visualization, HMI)

## System-Level – Current Production, Software/Hardware Engineering

1. Hardware includes Allen-Bradley (SLC 5/03, CompactLogix 1200/1400, and Safety PLC), Keyence Laser, Schneider Electric M340 and SoMachines, Modicon Magelis & Quantum, Phoenix Contact PLC (ILC series, including RF wireless solutions), Honeywell HC900/StationDesigner/Experion, Dell, Apple, Sony, Cognex, Matrox, Toshiba, Dalsa, and TrippLite.
2. Deployed using RSLogix 500 and RSView/PanelBuilder, Honeywell Tridium, Honeywell StationDesigner, VisualStudio.Net, MS SQL Server 2005/2008 (including Reporting Services), IIS 6/7, Wonderware & Historian (InSQL), Citect SCADA, Advantech DLL (I/O Extender), Matrox ActiveMIL DLL (C# machine vision), ASP.Net, VisualBasic.Net, Crystal Reports, C++ enumerated drivers implementing vendor-specific API's, VSTO/Exchange/VBA/COM automation.
3. Modbus RTU and Modbus/TCP driver development for several systems, including Wonderware, Phoenix Contact, Schneider/Modicon, Honeywell (industrial controllers and

Tridium Commercial HVAC), Multi-threaded, SQL-Server enabled architecture, including custom .Net executable development, and C++ driver development (laser displacement).

4. Statistical processing, online and offline in runtime (derived Excel spreadsheets, graphics, and automated scripting). Also, using Wonderware's Historian, building full real-time visualization interfaces for 21CFR Part 11 compliance in pharmaceutical manufacturing (client: Bayer).
5. Regulated verification of image and motion control data (Yaskawa)
6. Fully documented lifecycle, using Visio, Acrobat, Adobe Photoshop/Illustrator, AutoCAD, and Microsoft Office applications.

## User Interfaces – Graphics/multimedia & Industrial HMI

Industrial HMI includes Modicon (Schneider) Magelis, Allen-Bradley PanelView/PanelMate, Windows PC (server rack and workstations, including Advantech and Phoenix Contact), Watlow Silver Series (Maple Systems), Honeywell Station 900 Ultra, and OEM prototypes of various types.

Also, I have worked in prototype development of user interface for Windows/Mac standalones and Photoshop plug-in. Adobe-supported startup graphics application (color correction) using document-based workflow including real-time controls in UI thread. Windows apps written in C (Photoshop) and .Net (C#). Macintosh apps written in Cocoa (UI) and Carbon (Photoshop). Carbon libraries included production in HI, and Cocoa libraries included QuickTime Kit, Cocoa AppKit, and Java enterprise objects (Apple WebObjects).

## Industrial Control Applications

Using industrial MCU and commercial CPU architectures, I built real-time, multi-threaded applications with DLLs and analog/digital I/O. Using Windows.Net and IEC-level programs (function block, ladder, structured text), I built deterministic systems solutions for the past seven years. Kernel-level process viewing and profiling is necessary for this type of engineering. Also, I helped develop the motion controllers, machine vision controllers/cameras/optics/lighting, and PLC. Hardware controllers include Cognex InSight industrial camera, Dalsa linescanners (I/O, triggers, synch), framegrabbers @ 600 MB/sec+, micron-level scanning/optics, advanced lighting/illumination, audio dynamic range in hardware @ 104dB (unprecedented in most levels) with acoustics/vibration analysis. Clients included Taco Bell, Brookhaven Labs, Bayer, Golden State Water, Electrical Design & Motor Control, and various industrial forges in/around Los Angeles, CA. 2005 – Present.

## Visualization & Multimedia

On Macintosh and Windows (and their browsers), I have deployed several smaller applications including QuickTime movie viewer, Windows Media Player ActiveX control, Adobe Flash Control, “chat” instant messaging server, real-time, SSL-safe video streaming, real-time compression on Windows (HTTP/FTP) and Mac (HTTP). 2001 – Present.

## Databases and Accounting Packages Built

Clients included Trimark Engineering, Foundation Mortgage, Sacramento Water Forum, Saber Engineering. 2001 – 2009. Technologies used:

1. Industrial: Wonderware Historian (InSQL, Excel), SpecView, Honeywell TrendServer Pro, Nevron .Net Visualization Libraries, SQL Server Reporting Services
2. FileMaker Pro
3. VisualStudio.Net (ASP.Net, C#, VisualBasic, IIS, sqlcmd.exe)
4. Microsoft Office (VSTO, Wonderware Historian/InSQL, OPC, Access, Real-Time SQL Server 2005/2008 Integration including Reporting Services)
5. QuickBooks Pro

# Samples

(\*To RUN. IF HELD, then send RELEASE HOLD. IF STOPPED, then send RUN\*)

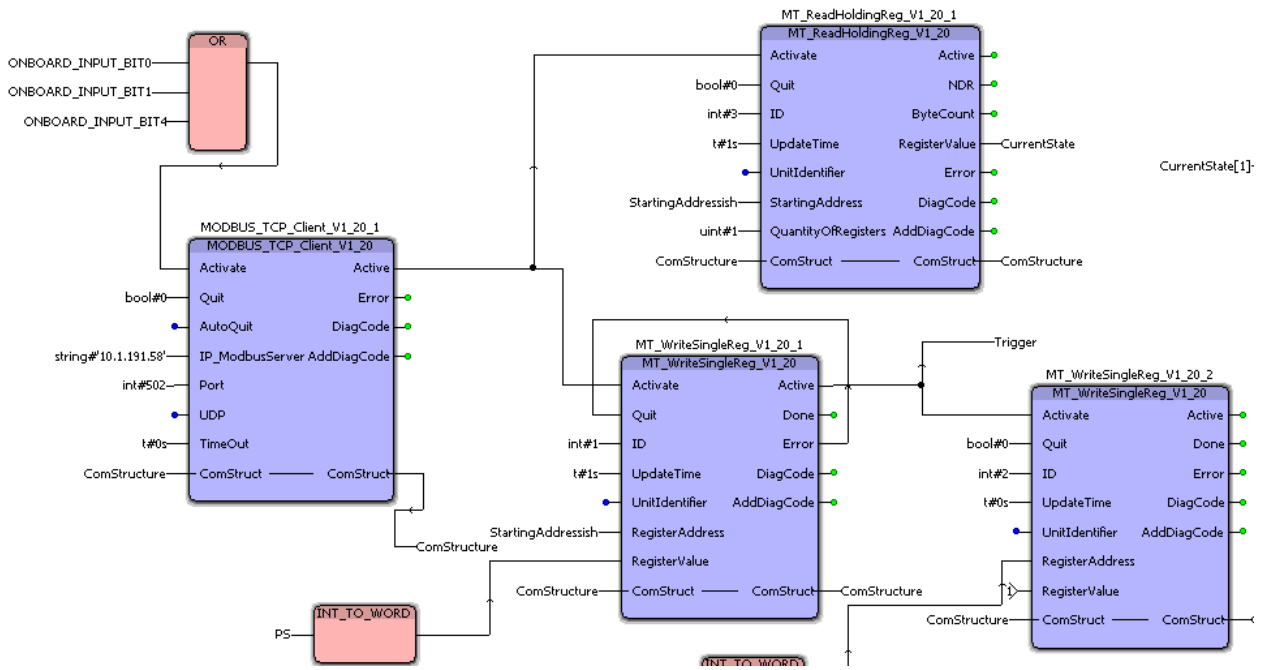
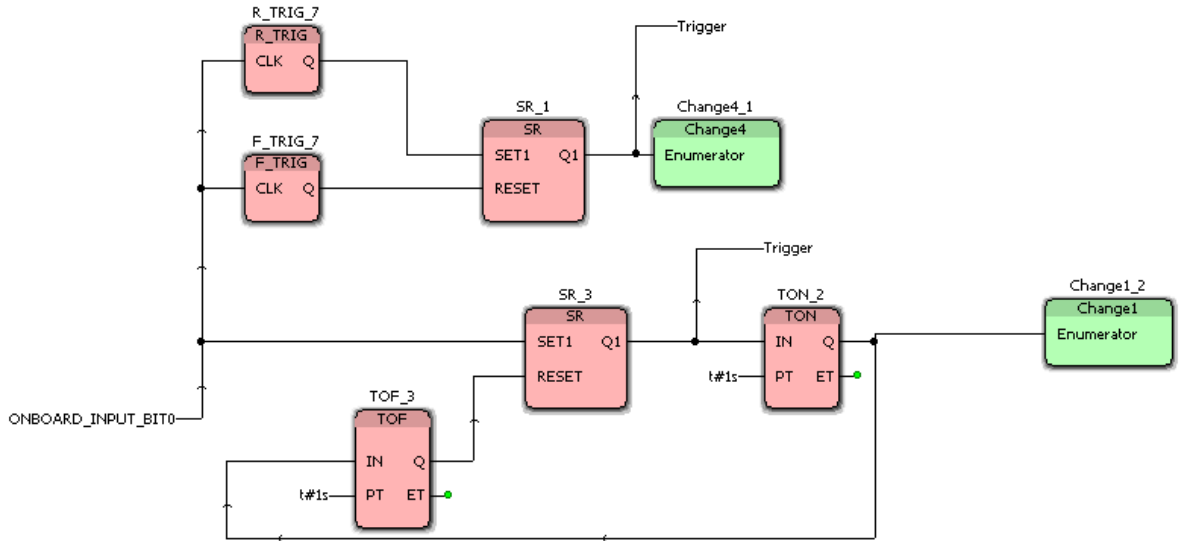



# Script Samples

## Wonderware 2 Script 1, scan rate: 5000 ms

{Daily Trend Report Error Checking}

IF DailyTrendPrintTimeHour >= DailyTrendEndTimeHour THEN

    IF DailyTrendPrintTimeHour == DailyTrendEndTimeHour AND DailyTrendPrintTimeMinute <=  
    DailyTrendEndTimeMinute

        THEN popupReturn = MessageBox("Please, enter a date/time for the END TIME that is earlier than  
the date/time TO BE PRINTED.", " Operator Date/Time Entry Invalid", 30);

        IF DailyTrendPrintTimeHour == 0 AND DailyTrendPrintTimeMinute == 0 THEN  
            DailyTrendPrintTimeMinute = 1;  
        ENDIF;

        {Otherwise, drop the EndTimeMinute by one minute behind the PrintTimeMinute}

        DailyTrendEndTimeHour = DailyTrendPrintTimeHour;  
        IF DailyTrendEndTimeMinute <> 0 THEN  
            DailyTrendEndTimeMinute = DailyTrendPrintTimeMinute - 1;  
        ENDIF;

    ENDIF;

ELSE

popupReturn = MessageBox("Please, enter a date/time for the END TIME that is earlier than the date/time  
TO BE PRINTED.", " Operator Date/Time Entry Invalid", 30);

    IF DailyTrendPrintTimeHour == 0 AND DailyTrendPrintTimeMinute == 0 THEN  
        DailyTrendPrintTimeMinute = 1;  
    ENDIF;

    {Otherwise, drop the EndTimeMinute by one minute behind the PrintTimeMinute}

    DailyTrendEndTimeHour = DailyTrendPrintTimeHour;  
    IF DailyTrendEndTimeMinute <> 0 THEN  
        DailyTrendEndTimeMinute = DailyTrendPrintTimeMinute - 1;  
    ENDIF;

ENDIF;

{Weekly Error Checking}

```
IF StringFromIntg(DayOfWeek,10) == "1" THEN DOWTag = "Sun";
ENDIF;
IF StringFromIntg(DayOfWeek,10) == "2" THEN DOWTag = "Mon";
ENDIF;
IF StringFromIntg(DayOfWeek,10) == "3" THEN DOWTag = "Tue";
ENDIF;
IF StringFromIntg(DayOfWeek,10) == "4" THEN DOWTag = "Wed";
ENDIF;
IF StringFromIntg(DayOfWeek,10) == "5" THEN DOWTag = "Thu";
ENDIF;
IF StringFromIntg(DayOfWeek,10) == "6" THEN DOWTag = "Fri";
ENDIF;
IF StringFromIntg(DayOfWeek,10) == "7" THEN DOWTag = "Sat";
ENDIF;
```

```
IF DOWTag == StringMid(LocalNow,1,3) THEN
```

```
    IF WeeklyPrintTimeHour >= WeeklyEndTimeHour THEN
```

```
        IF WeeklyPrintTimeHour == WeeklyEndTimeHour AND WeeklyPrintTimeMinute <=
WeeklyEndTimeMinute
```

```
            THEN
```

```
                popupReturn2 = MessageBox("Please, enter a date/time for the END TIME that is earlier than the
date/time TO BE PRINTED.", " Operator Date/Time Entry Invalid", 30);
```

```
            IF WeeklyPrintTimeHour == 0 AND WeeklyPrintTimeMinute == 0 THEN
```

```
                WeeklyPrintTimeMinute = 1;
            ENDIF;
```

```
            {Otherwise, drop the EndTimeMinute by one minute behind the PrintTimeMinute}
```

```
            WeeklyEndTimeHour = WeeklyPrintTimeHour;
```

```
            IF WeeklyEndTimeMinute <> 0 THEN
                WeeklyEndTimeMinute = WeeklyPrintTimeMinute - 1;
            ENDIF;
```

```
            IF DayOfWeek <> 1 THEN
                DayOfWeek = DayOfWeek - 1;
            ENDIF;
```

```
        ENDIF;
```

```
    ELSE
```

```
popupReturn2 = MessageBox("Please, enter a date/time for the END TIME that is earlier than the date/time TO BE PRINTED.", " Operator Date/Time Entry Invalid", 30);
```

```
IF WeeklyPrintTimeHour == 0 AND WeeklyPrintTimeMinute == 0 THEN  
    WeeklyPrintTimeMinute = 1;  
ENDIF;
```

```
{Otherwise, drop the EndTimeMinute by one minute behind the PrintTimeMinute}
```

```
WeeklyEndTimeHour = WeeklyPrintTimeHour;  
IF WeeklyEndTimeMinute <> 0 THEN  
    WeeklyEndTimeMinute = DailyTrendPrintTimeMinute - 1;  
ENDIF;
```

```
IF DayOfWeek <> 1 THEN  
    DayOfWeek = DayOfWeek - 1;  
ENDIF;
```

```
ENDIF;
```

```
ENDIF;
```

## Recent Winforms String Parser (non-XML)

```
Public Class Form1
```

```
    Private Sub Button1_Click(ByVal sender As System.Object, ByVal e As  
System.EventArgs) Handles Button1.Click
```

```
        'Declare a whole bunch of variables to handle parsing the string in  
TextBox1
```

```
        Dim i As Integer  
        ' Dim j As Integer  
        Dim counter As Integer  
        Dim strCounter As Integer  
        Dim s As String  
        Dim s1 As Char  
        Dim myString As String = "abcdefghijklmnopqrstuvwxy" ' This is the  
fastest type of initialization of this array in VB.Net  
        Dim myStringArray() As Integer = {0, 0, 0, 0, 0, 0, 0, 0, 0, 0, 0, 0,  
0, 0, 0, 0, 0, 0, 0, 0, 0, 0, 0, 0} ' avoids null exceptions  
explicitly  
        Dim listString() As String  
        Dim listBoxCounter As Integer  
  
        ' Get the text that is to be parsed:  
s = TextBox1.Text  
  
        ' Get the length of the string to be parsed:  
i = s.Length - 1
```

```

' Loop through the string to be parsed, one character at a time:
For strCounter = 0 To i

    ' Then, loop through the letters of the alphabet to see if it
    occurred in the current string's index:
    For counter = 0 To 25

        ' Increment an array that keeps track of the number of
        occurrences of each letter in the string to be parsed:
        If s.Substring(strCounter, 1) = myString.Substring(counter,
1) Then
            myStringArray(counter) = myStringArray(counter) + 1
        End If
    Next

Next

' Build a list box, and fill it with only with counters for the
letters which actually occurred in the string to be parsed:
For listBoxCounter = 0 To 25
    If myStringArray(listBoxCounter) > 0 Then

        ListBox1.Items.Add("There are " &
myStringArray(listBoxCounter) & " " & myString.Substring(listBoxCounter, 1) &
"s...")

    End If
Next

' Your string is parsed.  Have a nice day!

End Sub

End Class

```

## ASP.Net 2.x SQL Postback Prototype

```

<%@ Page Language="C#" MasterPageFile="~/BasicMaster.master" Title="Untitled
Page" %>

```

```

<script runat="server">

```

```

    protected void Page_Load(object sender, EventArgs e)
    {
        // This is where you handle page load event loop.  All application
        // state settings go in Web Configuration files.
    }

    protected void Button1_Click(object sender, EventArgs e)
    {
        // Constructor for SQL Table Modifier:

        SqlDataSource customerDataSource1 = new SqlDataSource();

```

```

        // Connection Strings:

        customerDataSource1.ConnectionString =
ConfigurationManager.ConnectionStrings["customerConnectionString"].ToString()
;

        // Set Inline SQL or Stored Procedure typing here

        customerDataSource1.InsertCommandType =
SqlDataSourceCommandType.Text;

        // Inline SQL Statements Here

        customerDataSource1.InsertCommand = "INSERT INTO customer1
(emailAddress, ipAddress, dateTimeStamp) VALUES (@emailAddress, @ipAddress,
@dateTimeStamp)";
        customerDataSource1.InsertParameters.Add("emailAddress",
emailAddressTextBox1.Text);
        customerDataSource1.InsertParameters.Add("ipAddress",
Request.UserHostAddress.ToString());
        customerDataSource1.InsertParameters.Add("dateTimeStamp",
DateTime.Now.ToString());

        // Check to see if there is a problem here...

int rowsAffected = 0;

try
{
    rowsAffected = customerDataSource1.Insert();
}
catch
{
    //Write to Windows Log
    Server.Transfer("EmailSubmitProblem.aspx");
}

finally
{
    customerDataSource1 = null;
}

if (rowsAffected != 1)
    Server.Transfer("EmailSubmitProblem.aspx");
else
{
    Server.Transfer("EmailSubmitThankYou.aspx");
}

    }
}

```



Mark Stephens  
August 11, 2008

To Whom It May Concern:

Pete Schieck has been developing and deploying the web site for my company, Tropical Imports. The types of chores we needed to address were to migrate older assets and IP to a new ASP.Net 3.5 architecture, HTML/CSS formatting of content, naming conventions for reusable assets, branding design, and ftp issues. Some marketing work was also done.

Some other work that will be considered in the future are: 1) databases for the wholesale portion of my business, 2) further work in automating the web/remote site, and 3) some e-commerce arrangements. One of the things that makes it easy to work with Pete is that he has a broad range of technical skills, so I don't have to go to multiple consultants to get this work done. My business has gone through some rapid changes, and Pete has been able to address my needs.

I am satisfied with Pete's work, so far, and will continue to work with Pete when I need him. I hope that anyone who is considering technology/web work, they will consider Pete.

Sincerely,

Mark Stephens  
owner, Tropical Imports